

Installation Manual
Use & Care Guide
Warranty Information

TOURBILLION SMART CONTROL KIT

Models:

205638 – for 60" No-Light/LED models
205639 – for 80" No-Light/LED models



Do not dispose of electrical appliances as unsorted municipal waste, use separate collection facilities. Contact your local council for more information regarding the collection systems available. If electrical appliances are disposed of in landfills or dumps, hazardous substances can leak into the ground water and get into the food chain, damaging your health and well-being.

EGLO Lighting has a policy of continual product improvement and development, dimensions, hardware and designs may change to reflect this policy. EGLO reserves the right to discontinue or change product specifications & designs at any time without notice and without incurring obligations. The images including all features and specifications in this manual are for illustrative purposes only. Product details, images & line drawings may vary depending on specific product models.

CONTENT:

FOR YOUR SAFETY:	4
SPECIFICATIONS:	4
INSTALLATION:	5
WIRING CONNECTIONS:	6
CODE LEARNING MODE:	6
SETTING UP THE SMART CONTROL KIT:	
NETWORK & ROUTER SETTINGS:	7
DOWNLOAD THE MY CONTROL APP:	7
CONFIGURE YOUR IN-APP HOME:	7
CONNECTING MY CONTROL DEVICES:	7
OPERATING YOUR SMART CONTROL KIT:	
OPERATING LIGHT FUNCTIONS:	8
OPERATING FAN FUNCTIONS:	8
OPERATING USING THE REMOTE CONTROL:	8
TROUBLESHOOTING:	8
WARRANTY:	
WARRANTY CLAIMS ON INSTALLED PRODUCTS:	9
AUSTRALIAN CONSUMER LAW:	9
LIMITED REPAIR / REPLACEMENT WARRANTY:	9
WARRANTY TRANSFER:	9
WHAT IS NOT COVERED:	9
COMMERCIAL USE:	10
WARRANTY CONDITIONS:	10
HOW TO MAKE A WARRANTY CLAIM:	10
WARRANTY CLAIM FORM:	11

Thank you for purchasing your new **EGLO Smart Control Kit**.
To ensure a safe and successful installation, please make sure to read this manual, ensure it is on hand for your installer to refer to, and keep in a safe place for future reference.

FOR YOUR SAFETY:

1. Please read this manual carefully before attempting the assembly or installation.
2. ALL electrical work should only be carried out by a suitably qualified and licenced electrical contractor. This smart control kit **MUST** be installed **ONLY** by a suitably qualified and licenced electrical contractor.
3. Before commencing any electrical work, ensure the power is disconnected and/or the mains switched off at the circuit box and ensure all pole isolation of the power supply.
4. Ensure that the fan and the hanging bracket must be earthed.
5. This appliance is not intended for use by persons (including children) with reduced physical, sensory, or mental capabilities, or lack of experience and knowledge, unless they have been given supervision or instruction concerning the use of the appliance by a person responsible for their safety.
6. Do **NOT** allow children to play with this appliance, and supervise children around electrical devices at all times.
7. Use **ONLY** the EGLO controller supplied with your fan, or a suitable EGLO controller designed specifically for your fan. Use of non-EGLO or solid-state dimmer type controllers can reduce speed and airflow, and can additionally damage your fan motor which cannot be repaired, and which will not be covered under warranty.
8. All EGLO products are warranted to be free from defects in workmanship and materials provided the products are used with a voltage supply within the range the product is designed to operate.
9. EGLO lighting will not be liable for any advice given to the consumer from any 3rd parties including suppliers, retailers & electricians.
10. The important safeguards and instructions in this manual are not designed to cover every possible condition or circumstance. It is understood that common sense, caution and care, are factors that cannot be built into the product, and those operating and maintaining this product must supply these factors.

SPECIFICATIONS:

Model	Input	Weight (NW)
205638 (for 60" No-Light / LED models)	220-240V~50Hz	150g
205639 (for 80" No-Light / LED models)	220-240V~50Hz	150g

INSTALLATION:

IMPORTANT: Check that the power is disconnected and/or the mains switched off at the circuit box to ensure all pole isolation of the power supply.

1. Loosen the 2 screws on the underside of the canopy. Refer Fig. 1, Twist the canopy anti-clockwise, and lower than canopy. Refer Fig. 2.
2. Disconnect the plug connectors; between receiver and terminal block, and the connectors between the receiver and the fan. Refer 'Wiring Connections'.
3. Remove the receiver from the mounting bracket and store. Refer Fig. 3.
4. Insert the new Smart Control Kit receiver into the mounting bracket. Refer Fig. 4.
5. Connect the plug connectors; between receiver and terminal block, and the connectors between the receiver and the fan. Refer 'Wiring Connections'.
6. Loosely coil all cables and gently tuck them around the mounting bracket. Raise the canopy up to the hanger bracket, and carefully tuck cables inside the canopy as you slowly raise it to the ceiling. Particular care must be given to ensure that no wires are damaged during this step, especially the remote antenna. Refer Fig. 5.
7. Align the canopy over the screws, and twist to lock in position, and tighten the 2 screws on the underside of the canopy.

Fig. 1

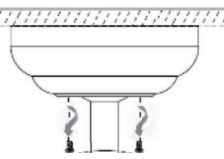

Fig. 2

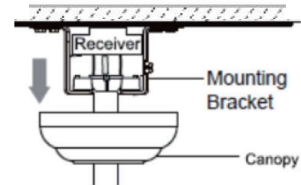

Fig. 3

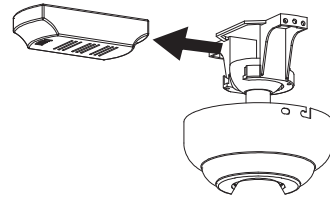

Fig. 4

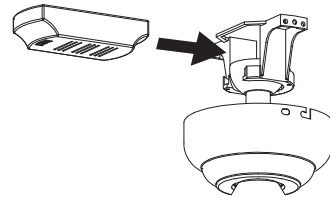
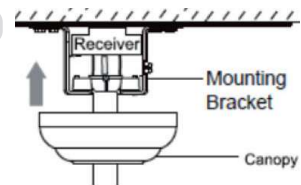

Fig. 5



Note: Models with light function have an additional plug connector for the light connection. Refer 'Wiring Connections'.

WIRING CONNECTIONS:

WARNING:
FOR YOUR SAFETY ALL ELECTRICAL CONNECTIONS MUST ONLY BE UNDERTAKEN BY A QUALIFIED AND LICENSED ELECTRICIAN.

WARNING: For safe use of the fan, an all-pole disconnection **MUST** be incorporated into the fixed wiring in accordance with the wiring rules. As outlined in clause 7.12.2 of AS/NZS 60335-1 for meeting the minimum electrical safety of this standard. Please note warranty will be void if the installation is without a means for an all-pole disconnection incorporated in the fixed wiring in accordance with the wiring rules.

A single pole isolation switch must be also placed in the same room as the fan as per local wiring regulations AS/NZS 3000, in accordance with clause 2.3.2.2.1 & 4.13.1.3 of AS/NZS 3000.

Note: If there are two or more ceiling fans installed in the one location/room, an isolation switch is required for **EACH** ceiling fan. This is required when programming any remote-control transmitter & receiver to pair together, and for fan servicing.

Note: The plug connector and wires "for light" not included on non-light app control kits.

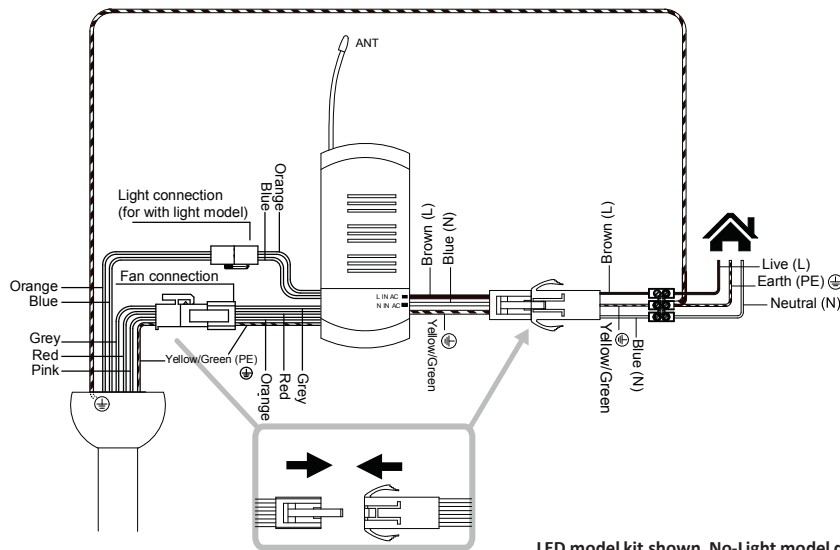

CODE LEARNING MODE:

SINGLE FAN INSTALLATION:

Note: Blades must be attached or fan will not continue to operate.

1. Connect wiring and switch the power supply ON, the receiver will make a beep sound.
2. **Within 30 seconds** of the receiver being powered on (connected) aim the transmitter towards the receiver and press "FAN OFF" button for 10 seconds or until a beep sound is heard meaning pairing/syncing has been successful.

Note: This must be done prior to fixing canopy in place.

3. Operate and test.
4. Complete assembly of canopy.

MULTIPLE FAN INSTALLATION:

Note: Blades must be attached or fan will not continue to operate.

Important: The pairing/syncing of each fan and remote **MUST** be done with all other fans disconnected from the power supply.

1. Fan #1 - Connect wiring and switch the power supply ON, the receiver will make a beep sound.
2. **Within 30 seconds** of the receiver being powered on (connected) aim the transmitter towards the receiver and press "FAN OFF" button for 10 seconds or until a beep sound is heard meaning pairing/syncing has been successful.

Note: This must be done prior to fixing canopy in place.

3. Operate and test.
4. **DO NOT** complete assembly of fan #1. Disconnect fan #1 from the power supply, or unplug the receiver to disconnect from terminal block.
5. Repeat steps 1-3 for each subsequent fan.
6. Only once all fans have been paired/synced and successful tested on separate remote control transmitters, can all fans then be reconnected to power, and assembly of canopy completed.

SETTING UP THE SMART CONTROL KIT:

NETWORK AND ROUTER SETTING:

Ensure you have a WiFi network, name and password that operates at 2.4Ghz to be compatible with my control products. Your IOS/Android device will need to be connected to this network when pairing or controlling your *My Control* device. A minimum WiFi strength of 2 bars is necessary to connect and control your device.

DOWNLOAD THE SMART CONTROL APP:

1. Download the mycontrol App from App Store or Google Play or scan the QR code.
2. Sign up to “create a new account”.
3. Follow the in-app prompt to complete the set up.



CONFIGURING YOUR 'IN-APP' HOME:

(Create a home enables the user to assign, allocate and share the devices easily)

Upon installation of the mycontrol App, tap “Me” located at the bottom right of the screen and select “Home Management”, then “Create your home”. Follow the prompts to complete your selections and tap “Save”. Refer Fig 8

Fig 8

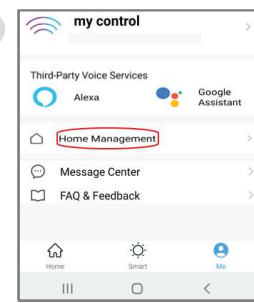

CONNECTING MY CONTROL DEVICES:

Follow the table and steps below to pair your devices.

1. Press and hold the “8H” button on your remote control for 2 to 3 seconds. When you hear a “beep” sound;
2. Open the App to the “Home” screen.
3. If your device have been discovered, go to (6).
4. From the App “Home” screen, tap “+” or “Add Device”. Refer Fig. 9.
5. "Select category "Small Home Appliances" > Fan (BLE+WiFi), and tap “Add” when your device appears, and follow the prompts. Refer Fig 10.
6. Discovering devices..., “Add” when your device appears, and follow the prompts.
7. Enter your 2.4GHz Wifi network name and Password (previously set up) and tap “Next”. Refer Fig. 11.
8. Follow the prompt to complete the pairing process.
9. Once your device is successfully added, you can “re-name” it and assign it to a room. Refer Fig. 12.

Fig 9

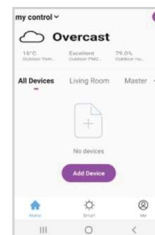

Fig 10

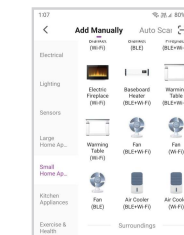

Fig 11

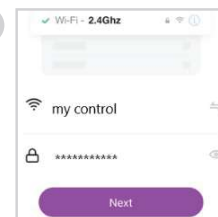

Fig 12



Note: Re-naming the device will enable better control when linking it with the compatible devices.

OPERATING YOUR APP CONTROL KIT:

Operating Light Functions: Refer Fig. 13.

Lamp Switch: Turns light On / Off
Countdown Off: (Light Timer) Set desired period until light turns off

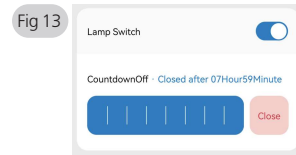

Operating Fan Functions: Refer Fig. 14.

Fan Switch: Turns fan On / Off
Fan speed: '1' = Speed 1
'2' = Speed 2
'3' = Speed 3
'4' = Speed 4
'5' = Speed 5

Fan Direction: Switch between 'Forward' / 'Reverse' mode
Countdown Off: (Fan Timer) Set desired period until fan turns off

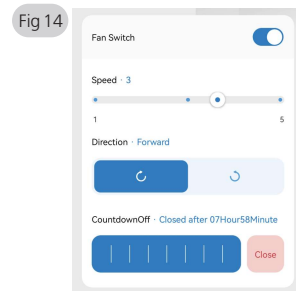

OPERATING USING THE REMOTE CONTROL:

Operating your fans via the remote control that came with the fan is the same as before. For detailed instructions about the functions of the remote controls, refer to the Instruction Manual supplied with the fan.

TROUBLE SHOOTING

If you are experiencing problems while setting up or operating, please refer to the troubleshooting section within the My Control App.

WARRANTY CLAIMS ON INSTALLED PRODUCTS:

EGLO Lighting (EGLO) will not be liable for charges incurred by the consumer for rectification, de-installation or re-installation unless approved by EGLO management in writing prior to commencing work.

All claims are to be submitted to EGLO Warranty Department with a copy of the original purchase receipt, copy of receipt from installation (inc electrical contractor licence number), and completed EGLO warranty claims form. Incomplete submission will result in delays processing your claim.

Any additional photos, videos or information that can be supplied at the time of submission, will help expedite your claim.

1. AUSTRALIAN CONSUMER LAW:

The benefits given to you the consumer in this warranty document are in addition to your other rights and remedies under a law in relation to the products to which this warranty document relates.

“YOUR CONSUMER RIGHTS”: “Our goods come with guarantees that cannot be excluded under the Australian Consumer Law. You are entitled to a replacement or refund for a major failure and compensation for any other reasonably foreseeable loss or damage. You are also entitled to have the goods repaired or replaced if the goods fail to be of acceptable quality and the failure does not amount to a major failure.”

Subject to “Your Consumer Rights” outlined above, but otherwise to the maximum extent permitted by law, EGLO will not be liable for any consequential or indirect loss or damage suffered or incurred by you in relation to an EGLO product, including but not limited to loss of use, loss or damage for business interruption, or profits.

2. LIMITED REPAIR / REPLACEMENT WARRANTY:

EGLO offers the purchaser a repair or replacement of the EGLO product in cases where the product fails due to defective materials or workmanship, when installed and operated under normal domestic conditions, for a period of 1 year. Please refer to the warranty period listed on each product to determine the warranty period which EGLO grants to the original purchaser of the EGLO product. The warranty period begins from the date of purchase. Also, please refer to WHAT IS NOT COVERED.

You must provide proof of purchase (such as the original dated purchase receipt/invoice) from an authorised EGLO reseller to make a warranty claim. You must also provide a receipt from installation, including the electrical contractors licence number - if an electrical licence number cannot be supplied, your claim will be denied. This warranty will not apply if the ceiling fan is installed by anyone other than a qualified and licensed electrical contractor.

Resetting/Changing of DIP switches in connected remote controls is not covered by warranty and a service call fee WILL apply.

Batteries (if supplied), are done so as a complimentary (free) item only, and are not covered by warranty.

REPAIRS / REPLACEMENTS

EGLO products presented for repair may be replaced by refurbished goods of the same type rather than being repaired at the discretion of EGLO. Refurbished parts may be used to repair the goods to proper order.

BALANCE OF WARRANTY

To the maximum extent permitted by law, any product replaced, repaired or refurbished by EGLO is covered only by the balance of the warranty period remaining from the date of original purchase of the original EGLO product.

4. WARRANTY TRANSFER:

If the ownership changes on the dwelling/premises where the EGLO product is installed, the balance of the warranty period passes to the new owner provided the original proof of purchase (such as the original dated purchase receipt) from an authorised EGLO retailer is retained by the new owner. In addition, proof of installation & licence number of the original installing electrician must be retained.

5. WHAT IS NOT COVERED:

Subject to “Your Consumer Rights”, but otherwise to the maximum extent permitted by law, the EGLO warranties provided in this document will not cover the following:

1. EGLO products that are not purchased from an authorised dealer in Australia and installed in Australia.
2. Where installation was not carried out by a qualified and licensed electrical contractor or where a valid Electrical Safety Certificate cannot be presented.
3. EGLO products not installed in accordance with the product’s installation instructions for use and/or specifications.
4. EGLO products not operated in accordance with the instructions for use, or specifications.
5. EGLO products that have been modified in any manner.
6. Defect, damage, or failure to a EGLO product resulting from misuse, accident, neglect, abuse, tampering, modifications or unauthorised repairs of any kind by any person.
7. Damages not caused by a fault in the EGLO product materials or workmanship.
8. Defect, damage, or failure to an EGLO product resulting from any acts of God, including damage from lightning, power grid fluctuations, or power surges.
9. Replacement of batteries supplied with certain products.
10. Damage caused by alternative power systems. (for example: ‘off grid’ etc.)

6. COMMERCIAL USE:

EGLO products which are specifically designed for commercial use are designated as Commercial Use Products on the product packaging. All other EGLO products are designed for domestic use only.

This product is not designed or intended for industrial or commercial use.

WARRANTY CONDITIONS:

- This warranty is for 240V 50Hz products originally purchased in, and installed in Australia ONLY.
- Installation must be performed by a qualified and licensed electrician. The warranty will not apply if the product is installed by other than a qualified and licensed electrician.
- Problems arising from incorrect installation are not covered by warranty.
- The cost of repairs and/or service call arising from incorrect installation, not due to faulty material or workmanship in accordance with the EGLO warranty, will be payable by the purchaser.
- This warranty is only valid for appliances used according to the manufacturer’s instructions.
- This warranty is only valid for remote controls connected/paired to EGLO AC ceiling fans.
- The manufacturer does not accept liability for any direct or consequential damage, loss or other expense arising from misuse or incorrect installation and operation of the appliance.
- Warranty will only be provided where proof of qualified electrical installation is provided. E.g. Electrical Safety Certificate.
- Warranty will not be provided if installation is without an all-pole disconnection incorporated in the fixed wiring in accordance with the wiring rules.

HOW TO MAKE A WARRANTY CLAIM:

Please return the faulty EGLO product together with a copy of the proof of purchase, and if required, a certificate of compliance for the installation of the product by the licensed electrician who installed the product, to the authorised EGLO retailer where the product was purchased. To the maximum extent permitted by law, the customer must bear the costs and expenses of claiming under this warranty, including but not limited to the cost incurred in freight, postage, handling, travel, dismantling or reinstalling the product.

IN THE CASE OF MISSING ACCESSORIES OR PARTS, PLEASE CONTACT EGLO CUSTOMER SERVICE BEFORE COMMENCING INSTALLATION OF THE PRODUCT. IF YOUR PRODUCT IS DEFECTIVE OR EXCESSIVELY NOISY, PLEASE FIRST REFER TO THE TROUBLE SHOOTING SECTION OF THIS MANUAL AND PERFORM ALL CHECKS, AND THEN CONTACT EGLO CUSTOMER SERVICE BEFORE THE ELECTRICIAN LEAVES THE RESIDENCE WHERE THE INSTALLATION IS TAKING PLACE.



WARRANTY CLAIM FORM

Warranty Claim No.:
(EGLO Office Use Only)

To help us assist you with your claim, please complete the enclosed warranty form in full.

CUSTOMER DETAILS

Name:			
Daytime Phone/Mobile:			
Email:			

ADDRESS WHERE PRODUCT IS INSTALLED

Address:					
Suburb/Town:		State:		Postcode:	

STORE PURCHASED FROM

Store Name:			
Date of Purchase:			

INSTALLATION DETAILS

Electrician Business Name:			
Electrician Name:		Electrician Licence No.:	
Installation Date:		Electrician Phone/Mobile:	
Electrician Email:			

PRODUCT DETAILS

Series Name:		Model Number:	
Remote Control Accessory:	Yes <input type="checkbox"/> No <input type="checkbox"/>	Remote Model No.:	
DC Wall Control Accessory:	Yes <input type="checkbox"/> No <input type="checkbox"/>	DC Wall Control Model No.:	
Fault Details:			

CHECKLIST - Have you supplied?

- Receipt of purchase: Yes No
- Receipt of installation/electrical safety certificate: Yes No
- photos / videos that may help fast track claim: Yes No

I confirm that I have an isolation switch installed for EACH of the ceiling fan(s) associated with this Warranty Claim. I understand that my claim cannot be processed if an isolation switch is not installed.

Please email this form, together with copy of your purchase receipt & electricians' invoice to:

EGLO LIGHTING AUSTRALIA
warranty@eglolighting.com.au

For assistance with your claim please phone:
1800 254 448



EGLO LIGHTING AUSTRALIA

5/339 Archerfield Road
Richlands
Queensland 4077
www.eglo.com.au