



Do not dispose of electrical appliances as unsorted municipal waste, use separate collection facilities. Contact your local council for more information regarding the collection systems available. If electrical appliances are disposed of in landfills or dumps, hazardous substances can leak into the ground water and get into the food chain, damaging your health and well-being.

EGLO Lighting has a policy of continual product improvement and development, dimensions, hardware and designs may change to reflect this policy. EGLO reserves the right to discontinue or change product specifications & designs at any time without notice and without incurring obligations. The images including all features and specifications in this manual are for illustrative purposes only. Product details, images & line drawings may vary depending on specific product models.

CONTENT

FOR YOUR SAFETY:	4
BEFORE INSTALLATION:	4
INSTALLATION:	5
WIRING CONNECTIONS:.....	6
OPERATING YOUR REMOTE CONTROL:	6
TROUBLE SHOOTING:.....	7
WARRANTY CLAIMS ON INSTALLED PRODUCTS:.....	8
1. AUSTRALIAN CONSUMER LAW:.....	8
2. LIMITED REPAIR / REPLACEMENT WARRANTY:	8
4. WARRANTY TRANSFER:	8
5. WHAT IS NOT COVERED:	8
6. COMMERCIAL USE:	9
WARRANTY CONDITIONS:.....	9
HOW TO MAKE A WARRANTY CLAIM:	9

Thank you for purchasing your new **EGLO remote control**.

To ensure a safe and successful installation, please make sure to read this manual, ensure it is on hand for your installer to refer to, and keep in a safe place for future reference.

FOR YOUR SAFETY:

1. Please read this manual carefully and save it for later use.
2. ALL electrical work should only be carried out by a suitably qualified and licenced electrical contractor. This remote control must be installed ONLY by a suitably qualified and licenced electrical contractor.
3. This device is not intended for use by persons (including children) with reduced physical, sensory, or mental capabilities, or lack of experience and knowledge, unless they have been given supervision or instruction concerning the use of the appliance by a person responsible for their safety.
4. Do NOT allow children to play with this device and supervise children around electrical devices at all times.
5. Before commencing any electrical work, ensure the power is disconnected and/or the mains switched off at the circuit box and ensure all pole isolation of the power supply.
6. Do not install the remote control together with an existing wall controller. Replace existing wall controller with a double pole wall switch to power/isolate the remote control.
7. The remote controller must not share a wiring circuit with any electrical equipment that is sensitive to voltage fluctuation, such as security lighting with infrared sensors.
8. Do not use a solid-state dimmer with this ceiling fan remote.
9. All EGLO products are warranted to be free from defects in workmanship and materials provided the products are used with a voltage supply within the range the product is designed to operate.
10. This remote control is designed for use indoors only. Do not install in damp locations.
11. Do not exceed the rated power input specifications.
12. Do not pull or cut any wires.
13. Do not drop or bump the remote control transmitter or receiver.
14. Batteries must be replaced regularly.
15. This remote control is only suitable for controlling a ceiling fan motor and light kit connected to a ceiling fan, any other use would be considered misuse.
16. This remote control is only suitable where the receiver can be safely and securely inserted into the hanger bracket.
17. EGLO lighting will not be liable for any advice given to the consumer from any of our suppliers or third parties, related or otherwise.
18. The important safeguards and instructions in this manual are not designed to cover every possible condition or circumstance. It is understood that common sense, caution, and care are factors that cannot be built into the product, those using and maintaining this product must supply these factors.

BEFORE INSTALLATION:

This remote controller has been designed to control your ceiling fan speed and light. There are 4 speeds, Fan ON/OFF, Light ON/OFF, Light Step Dimming and Timer functions, which will allow the flexibility to control your fan, your way.

Your EGLO remote control requires 2 x AAA batteries (included) to operate. Ensure only quality batteries are used and replace batteries regularly.

Specifications

Model:	205222
Input:	220-240V, 50/60Hz
Rating:	Fan: 100W (min. 15W), Light: 300W (min. 5W)
Frequency:	433.92MHz
Weight:	220g

INSTALLATION:

IMPORTANT: Check that the power is disconnected, and/or the mains switched off at the circuit box to ensure all pole isolation of the power supply.

Note: For safe use of the connected fan, and all-pole disconnection **MUST** be incorporated into the fixed wiring in accordance with the wiring rules, as outlined in clause 7.12.2 of AS/NZS 60335-1 for meeting the minimum electrical safety of this standard. A single-pole switch also must be placed in the same room as the fan as per local wiring regulations AS3000.

Note: If there are two or more ceiling fans installed in the one location/room, an isolation switch is required for EACH ceiling fan.

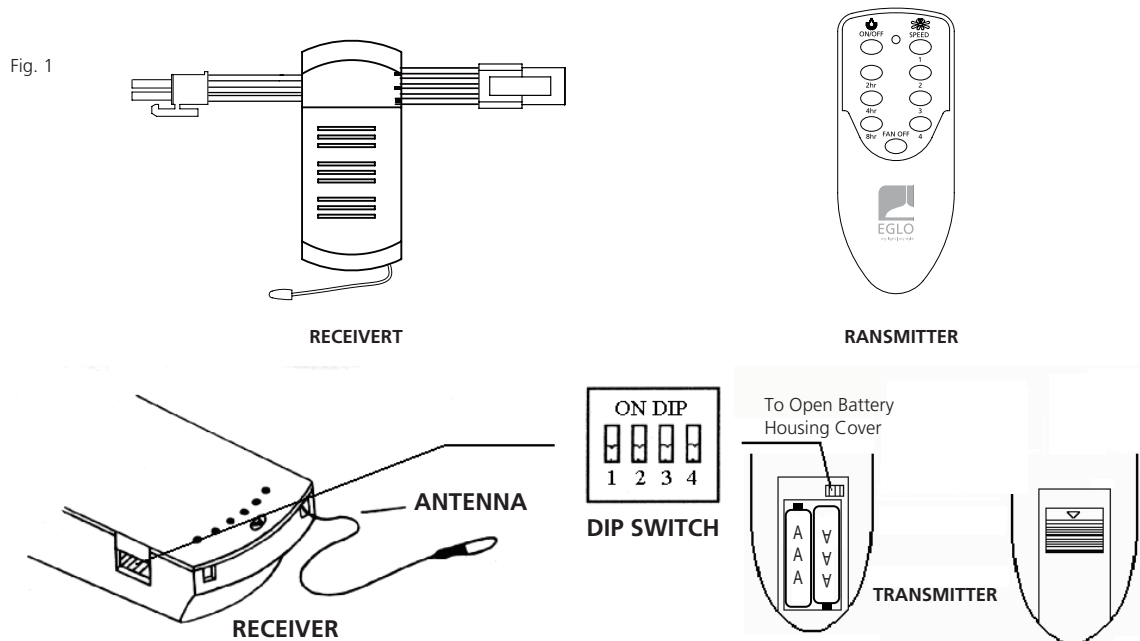

1. The remote transmitter and receiver must be configured so that the receiver and transmitter are paired together to allow communication. Set the DIP switches on **BOTH** the transmitter and receiver to be **ON THE SAME SETTING**. The DIP switches are located in the battery compartment of the transmitter, and on the side of the receiver.
2. For each fan, set the transmitter's code and then set the same code on the receiver, and double check they are the same. Every ceiling fan must be operating from its own unique code.
3. Remove the battery cover from the back of the remote transmitter and insert 2 x AAA batteries (included), ensuring the polarities are correct as shown in the battery compartment, and that the batteries are fresh batteries.
4. Lower the ceiling fan canopy from the ceiling and disconnect the wiring by unplugging the plug connectors.
5. Connect the remote receiver plug connectors to mains supply, and to fan/light.
6. Starting with the black antenna, slide the receiver into the hanger bracket as shown. (Refer Fig 2)
7. Reattach the ceiling fan canopy, ensuring the antenna is not damaged, and located where it will receive the signal from the transmitter. (Refer Fig 3)
8. Test the operation.
9. Install the transmitter wall holder using the screws provided, taking care not to damage cables located within the wall cavity. (Refer Fig 4)

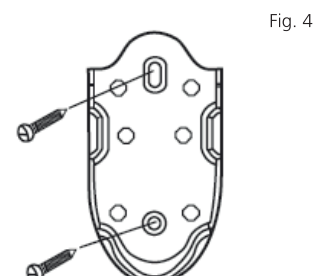
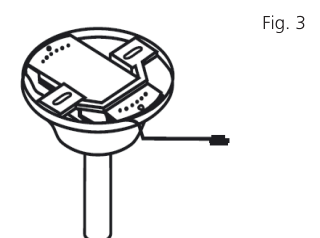
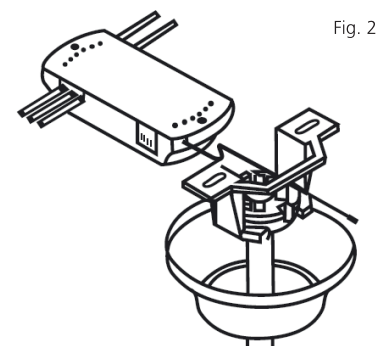

WIRING CONNECTIONS:

WARNING:
FOR YOUR SAFETY ALL ELECTRICAL CONNECTIONS MUST ONLY BE UNDERTAKEN BY A QUALIFIED AND LICENSED ELECTRICIAN.

Note: For safe use of the connected fan, and all-pole disconnection **MUST** be incorporated into the fixed wiring in accordance with the wiring rules, as outlined in clause 7.12.2 of AS/NZS 60335-1 for meeting the minimum electrical safety of this standard.

A single-pole switch also must be placed in the same room as the fan as per local wiring regulations AS3000.

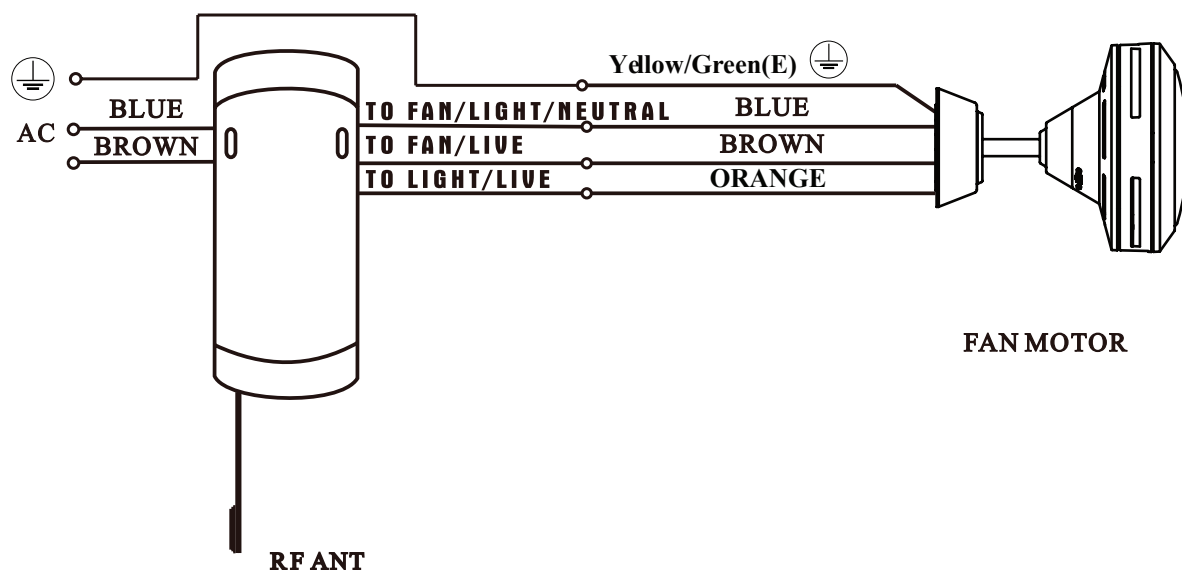

OPERATING YOUR REMOTE CONTROL:

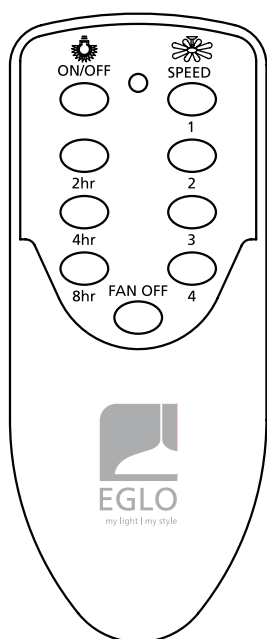

- FAN OFF:** Turn ceiling fan off.
- 4 Speed:** Turn ceiling fan on at high speed.
- 3 Speed:** Turn ceiling fan on at medium speed.
- 2 Speed:** Turn ceiling fan on at low speed.
- 1 Speed:** Turn ceiling fan on at night mode.



- ON/OFF:** Press and release to turn light on or off.
 Press off/on again within 3 seconds for dim to 50%*
 Press off/on again within 3 seconds for dim to 25%*
 Press off/on again within 3 seconds to return to 100%*
 Press off exceed 3 seconds and turn on, light return to 100%*

- 2hr:** Ceiling fan and Light will turn off in 2 hours.
- 4hr:** Ceiling fan and Light will turn off in 4 hours.
- 8hr:** Ceiling fan and Light will turn off in 8 hours.

* **Note:** Only for light source/s capable of step dimming

TROUBLE SHOOTING:

**WARNING:
FAN MUST BE SWITCHED OFF AND ISOLATED BEFORE COMMENCING ANY TROUBLE SHOOTING**

PROBLEM	POSSIBLE CAUSE	POSSIBLE REMEDY
No functions operate	Main power not restored.	(*) Replace fuse. Turn ON circuit breaker. Turn ON wall switch.
	Wall controller is not removed and interferes with remote operation.	(*) Remove the fan wall controller and replace with ON/OFF switch for remote.
	Wall switch-power to the fan remote is OFF.	Switch wall switch ON, to power the remote.
	Receiver wiring incorrect.	(*) Verify wiring connections according to label and wiring diagram.
	Transmitter and receiver DIP switches do not match.	Set transmitter and receiver to same DIP switch setting.
	The remote is too far from the receiver	Move closer to receiver.
Operates only at close range	Signal blocked from reaching receiver	Extend antenna out from canopy or move it for better reception.
	Battery too weak.	Replace with all new batteries. Do not mix up the old and new battery.
More than one fan remote operating. Interference in same area.	RF interference.	Change DIP switch settings to a different code. Each pair of transmitter and receiver must have unique DIP switch code.
Remote reset to default value	Batteries lost contact by accidental dropping of the remote, or battery is weak	Reset the setting as you preferred manually, after re-fitting batteries or change of new batteries.

(*) May require the assistance of a qualified and licenced electrical contractor.

WARRANTY CLAIMS ON INSTALLED PRODUCTS:

EGLO Lighting (EGLO) will not be liable for charges incurred by the consumer for rectification, deinstallation or reinstallation unless approved by EGLO management in writing.

All claims are to be submitted in writing to head office with a copy of the original purchaser's receipt, a copy of the certificate of compliance and a completed Warranty Claims Form. Incomplete submissions will not be considered.

1. AUSTRALIAN CONSUMER LAW:

The benefits given to you the consumer in this warranty document are in addition to your other rights and remedies under a law in relation to the products to which this warranty document relates.

"YOUR CONSUMER RIGHTS": "Our goods come with guarantees that cannot be excluded under the Australian Consumer Law. You are entitled to a replacement or refund for a major failure and compensation for any other reasonably foreseeable loss or damage. You are also entitled to have the goods repaired or replaced if the goods fail to be of acceptable quality and the failure does not amount to a major failure."

Subject to "Your Consumer Rights" outlined above, but otherwise to the maximum extent permitted by law, EGLO will not be liable for any consequential or indirect loss or damage suffered or incurred by you in relation to an EGLO product, including but not limited to loss of use, loss or damage for business interruption, or profits.

2. LIMITED REPAIR / REPLACEMENT WARRANTY:

EGLO offers the original purchaser a repair or replacement of the EGLO product in cases where the product fails due to defective materials or workmanship when installed and operated under normal domestic/residential conditions for 1 year from the date of original purchase. The warranty period begins from the date of purchase. Also, please refer to WHAT IS NOT COVERED.

You must provide proof of purchase (such as the original dated purchase receipt/invoice) from an authorised EGLO reseller to make a warranty claim. You must also provide a certificate of compliance or installers invoice including qualified installers licence number. Warranty claims submitted without this documentation WILL NOT BE ACCEPTED. This warranty will not apply if the ceiling fan and remote control is installed by anyone other than a qualified and licensed electrical contractor.

REPAIRS / REPLACEMENTS

EGLO products presented for repair may be replaced by refurbished goods of the same type rather than being repaired at the discretion of EGLO. Refurbished parts may be used to repair the goods to proper order.

BALANCE OF WARRANTY

To the maximum extent permitted by law, any product replaced, repaired or refurbished by EGLO is covered only by the balance of the warranty period remaining from the date of original purchase of the original EGLO product.

4. WARRANTY TRANSFER:

If the ownership changes on the dwelling/premises where the EGLO product is installed, the balance of the warranty period passes to the new owner provided the original proof of purchase (such as the original dated purchase receipt) from an authorised EGLO retailer is retained by the new owner. In addition, a certificate of compliance for the installation as required by law from the installing electrician is required for products requiring installation by licensed electricians.

Failure to transfer of these documents will result in the balance of the warranty being void.

5. WHAT IS NOT COVERED:

Subject to "Your Consumer Rights", but otherwise to the maximum extent permitted by law, the EGLO warranties provided in this document will not cover the following:

1. EGLO products that are not purchased from an authorised dealer in Australia and installed in Australia.
2. Where installation was not carried out by a qualified and licensed electrical contractor or where a valid Electrical Safety Certificate cannot be presented.

3. EGLO products not installed in accordance with the product's installation instructions for use and/or specifications.
4. EGLO products not operated in accordance with the instructions for use, or specifications.
5. EGLO products that have been modified in any manner.
6. Defect, damage, or failure to a EGLO product resulting from misuse, accident, neglect, abuse, tampering, modifications or unauthorised repairs of any kind by any person.
7. Damages not caused by a fault in the EGLO product materials or workmanship.
8. Defect, damage, or failure to an EGLO product resulting from any acts of God, including damage from lightning, power grid fluctuations, or power surges.
9. Replacement of batteries supplied with certain products.
10. Damage caused by alternative power systems (for example: solar inverters, etc.).

6. COMMERCIAL USE:

EGLO products which are specifically designed for commercial use are designated as Commercial Use Products on the product packaging. All other EGLO products are designed for domestic use only.

This product is not designed or intended for industrial or commercial use.

WARRANTY CONDITIONS:

- This warranty is for 240V 50Hz products originally purchased and installed in Australia.
- Installation must be performed by a qualified and licensed electrician. The warranty will not apply if the product is installed by other than a qualified and licensed electrician.
- Problems arising from incorrect installation are not covered by warranty.
- The cost of repairs arising from incorrect installation, and not due to faulty material or workmanship in accordance with the EGLO warranty, will be payable by the purchaser at the time of repair.
- This warranty is only valid for appliances used according to the manufacturer's instructions.
- This warranty is only valid for remote controls connected/paired to EGLO AC ceiling fans.
- The manufacturer does not accept liability for any direct or consequential damage, loss or other expense arising from misuse or incorrect installation and operation of the appliance.
- Warranty will only be provided where proof of qualified electrical installation is provided. E.g. Electrical Safety Certificate.
- Warranty will not be provided if installation is without an all-pole disconnection incorporated in the fixed wiring in accordance with the wiring rules.

HOW TO MAKE A WARRANTY CLAIM:

Please return the faulty EGLO product together with a copy of the proof of purchase, and if required, a certificate of compliance for the installation of the product by the licensed electrician who installed the product, to the authorised EGLO retailer where the product was purchased. To the maximum extent permitted by law, the customer must bear the costs and expenses of claiming under this warranty, including but not limited to the cost incurred in freight, postage, handling, travel, dismantling or reinstalling the product.

IN THE CASE OF MISSING ACCESSORIES OR PARTS, PLEASE CONTACT EGLO CUSTOMER SERVICE BEFORE COMMENCING INSTALLATION OF THE PRODUCT. IF YOUR PRODUCT IS DEFECTIVE OR UNRESPONSIVE, PLEASE FIRST REFER TO THE TROUBLE SHOOTING SECTION OF THIS MANUAL AND PERFORM ALL CHECKS, AND THEN CONTACT EGLO CUSTOMER SERVICE on 1800 254 448 BEFORE THE ELECTRICIAN LEAVES THE RESIDENCE WHERE THE INSTALLATION IS TAKING PLACE.





To help us assist you with your claim, please complete the enclosed warranty form in full.

WARRANTY CLAIM FORM

APPROVAL NO:

PURCHASE DETAILS			
Store Name:			
Date of Purchase:		Receipt:	YES <input checked="" type="checkbox"/> NO <input checked="" type="checkbox"/>
Contact Person:		Store Ph.:	
Email:			

CUSTOMER DETAILS			
Name:			
Address:			
City, Suburb:		State:	
Postcode:		Ph-Home:	
Ph-Mobile:		Ph-Work:	
Email:			

INSTALLER DETAILS			
Name:			
Licence No.:		Install Date:	
Cert of Elect Safety:	YES <input checked="" type="checkbox"/> NO <input checked="" type="checkbox"/>	PH - Mobile:	
Email:			

PRODUCT DETAILS			
EGLO Model No.:	205222 <input checked="" type="checkbox"/>	Connected EGLO Fan Name:	
Fault Details:			

EGLO USE ONLY			
Date:		Electrician:	
Quote No.:		Cost to Rectify:	
Approved By:		Signed:	

Please email this form, together with a copy of your purchase receipt, and installers invoice to **EGLO LIGHTING: warranty@eglolighting.com.au**, or call **1800 254 448** for assistance.



EGLO LIGHTING AUSTRALIA

5/339 Archerfield Road
Richlands
Queensland 4077
www.eglo.com.au