



HEATFLOW

Bathroom Heater/Fan/Light  
Model 204156/204157



### Installation Manual

## Please read these instructions

Thank you for purchasing your new EGLO Bathroom Heater/Exhaust/Light. To ensure a safe and successful installation, please make sure to read this manual, ensure it is on hand for your installer to refer to and keep in a safe place for future reference.

## For your safety

1. ALL electrical work should only be carried out by a licenced electrical contractor in accordance with AS NZS 3000.
2. This appliance is not intended for use by persons (including children) with reduced physical, sensory, or mental capabilities, or lack of experience and knowledge, unless they have been given supervision or instruction concerning the use of the appliance by a person responsible for their safety.
3. Before commencing any electrical work, ensure the power is disconnected and/or the mains switched off at the power supply.
4. This product has been designed to operate on a nominal supply voltage of 230 -240V AC.
5. The Bathroom Heater/Exhaust/Light unit must be earthed.
6. Disconnection may be achieved by having the plug accessible, or by incorporating a switch into the fixed wiring in accordance with wiring rules. The Bathroom Heater/Exhaust/Light must be isolated by means of a plug or all-pole disconnection switch with a contact separation of at least 3mm in each pole.
7. Use the Instant Heat only as described in this instruction, other use may cause fire or electric shock.
8. This product has been designed for INDOOR domestic or similar uses and is not suitable for a commercial installation. It is not suitable for use in an environment heavily-laden with dust and/or corrosive areas. Under these conditions the life of the fan motor can be significantly reduced.
9. The bulbs are hot when in use. Do not touch the infrared bulbs with any part of your body when in use. Allow all bulbs to cool sufficiently before touching or replacing.
10. The bulbs on this product should be tightened until fit is secure. Over tightening may damage the bulbs and under tightening may result in hot joints.
11. This product contains no serviceable parts and no attempt should be made to repair this product.
12. Regular cleaning of dust and contaminants should be done with ONLY a damp cloth, solvents should never be used.
13. This product has been designed to operate in ambient temperatures up to 40°C.
14. This product is to be installed so that switches CANNOT be touched or operated by a person in the bath or shower.
15. Joists, beams and rafters must not be cut, notched or damaged in the installation of this product.
16. Airflows listed in this product indicate the product performance. Refer to the BCA (Building Code of Australia), or similar, for the appropriate number of room air changes required for a particular installation.
17. Ventilation products must have an adequate source of external air to ensure rated performance can be achieved.
18. The ducting of the Bathroom Heater/Exhaust/Light must not be put in the same flue as air-fuelled water heaters or open-fire appliances.
19. This product should not be enclosed in thermal insulation as it may cause the unit to overheat.
20. This product should not be operated for more than 40 minutes continuously, turn off when not in use.
21. The terminals on this product should not be over-tightened. Over tightening may damage the product, under tightening may result in hot joints.
22. This unit is for ceiling mounting only, a minimum 2.1m above floor level. Do not install in wardrobes or within 250mm of walls. There is a danger of combustion if placed too close to curtains or other flammable materials.
23. Consideration must be taken in the installation of ducts to ensure that condensation that will form in the duct will not run back in to the fan housing.
24. The material in this product may vary in colour from batch to batch. Colour matching from one batch to another cannot be guaranteed.
25. After installation this product must be tested as required by the appropriate government and/or statutory regulations.
26. EGLO lighting will not be liable for any advice given to the consumer from any of our suppliers or third parties, related or otherwise.
27. The important safeguards and instructions in this manual are not designed to cover every possible condition or circumstance. It is understood that common sense, caution and care are factors that cannot be built into the product, those using and maintaining this product must supply these factors.

## Parts list

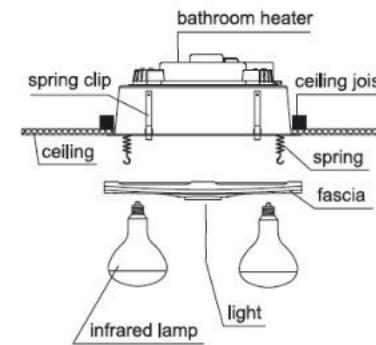

Operation unit	1 piece
Infrared lamp (E27)	4 pieces
13 W LED Panel Light	1 piece
Installation instruction & hole-cutting template	1 piece
Ventiduct kit	1 set
Duct clip	1 piece Ø120mm, 2 pieces Ø150mm
Switch	1 piece
Exterior vent	1 piece

## Specifications

Model number	204156/204155
Rated Voltage	230-240 VAC
Rated Frequency	50 Hz
Rated Power	1080-1180 W

EGLO Lighting has a policy of continual product improvement and development, dimensions, hardware and designs may change to reflect this policy. EGLO reserves the right to discontinue or change product specifications & designs at any time without notice and without incurring obligations. The images including all features and specifications in this manual are for illustrative purposes only. Product details, images & line drawings may vary depending on specific product models.

## Installation considerations

- The unit must not be installed directly above a shower or bath. The unit must not be installed where water may splash onto the bulbs.
- The unit must not be installed beneath a fixed socket.
- The unit is designed for installation on flat ceilings only. Do not install on sloping ceiling or on a vertical wall.
- The infrared heating bulbs are most effective when you are standing directly beneath them, install the unit above where you would stand to dry yourself. To obtain the best heating effect, there should be about 2.3m from the bulbs to the floor.
- For the exhaust fan to work effectively, replacement air of a volume equivalent to what is being extracted must be able to enter the room. If the room is airtight, leave a door or window open slightly to allow enough airflow.
- Before commencing installation, check the ceiling space to ensure there are no obstructions such as ceiling joists, and that there is sufficient height clearance for the housing.

## Installation

1. Turn the power OFF.
2. Locate a desired position on the ceiling, do not cut a hole yet.
3. As the duct is only 3.0 m, make sure that the distance from the centre of the installation position is not more than 3.0 m from the exterior vent outlet. It is not recommended to use ducting longer than 3.0 m as this will lower the performance of the exhaust fan. Check desired position suits duct length.

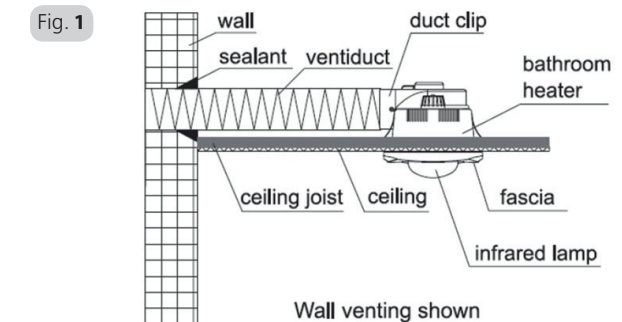

4. Locate a position for the exterior vent on the wall not more than 3.0 m from the unit, and allows the ducting to remain straight. (Refer Fig. 1)

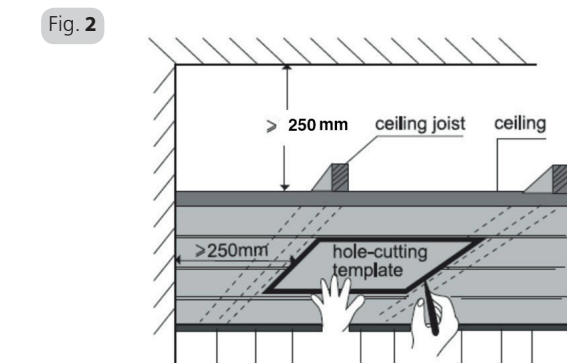

5. Place this template against the ceiling and use this template to mark the hole outline on the ceiling, ensuring there is minimum 250mm between the edges of the unit and any wall, and minimum cavity height of 250mm. Cut the hole for the unit. (Refer Fig. 2)
6. Keep unit clear from insulation, use a barrier to keep loose-filled insulation material away from unit.
7. Cut a 155mm diameter hole for the exterior vent outlet.
8. Connect one end of the ducting to the exterior vent with the duct clips provided, and let the other end enter the room through the hole into the vent hole and seal the space around the hole.
9. Remove all bulbs from the unit, unclip the internal fascia retaining springs inside the housing, unplug the LED at the connector and remove the fascia.
10. Connect one end of the interconnecting cable wire with the switch panel.

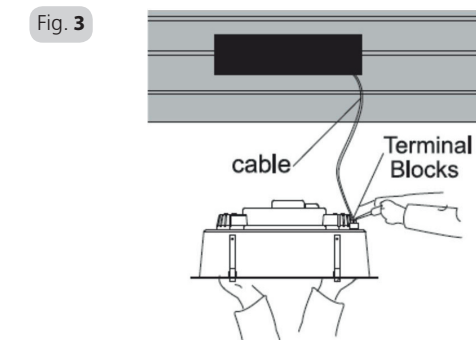

11. Open the terminal block cover on the housing and make connections as per wiring diagram and reattach the terminal block cover. (Refer Fig. 3)
12. Attach the end of the ducting to the adapter, and fit the adapter to the unit outlet, and secure with the duct clips provided.

Fig. 4

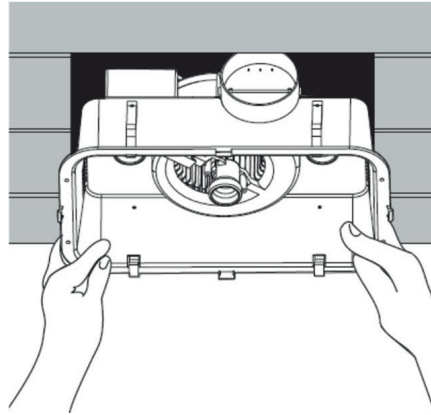

13. Position the Bathroom Heater/Exhaust/Light unit into the hole, making sure the duct outlet is aligned with the exterior vent, ensure all cabling is away from the housing, and secure in place with the side spring clips. (Refer Fig. 4)
14. Fix the housing into the ceiling using the four wooden screws.

**Note:**

Fixing screws included are for timber fixings only, for all alternate fixing materials, appropriate screws must be sourced by the installer or consumer.

15. Plug in the downlight and attach the fascia to the unit using the internal fascia retaining springs inside the housing.
16. Install the bulbs until fit is secure, do not over-tighten or under-tighten.
17. Clean the bulbs and fascia.
18. Attach the switch panel to the wall.

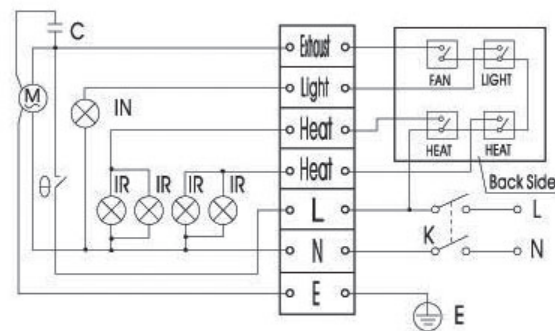
**Wiring Diagram**

M: Motor C: Capacitor IR: Heat lamp IN: Light lamp  
K: All-pole disconnection switch  $\theta$ : Heat protector

**Note:**

This unit is fitted with a thermostat switch which will automatically switch the exhaust fan ON, in the event the heat bulbs are left on, and the internal temperature exceeds 90°C.

**Operation**

- Heat1: Turn 'HEAT' switch on/off.  
Switches two heat lamps on, do not touch while they are in use.
- Heat2: Turn 'HEAT' switch on/off.  
Switches four heat lamps on, do not touch while they are in use.
- Fan: Turn 'FAN' switch on/off.  
The exhaust fan will extract the steam and odours quickly and efficiently.
- Light: Turn 'LIGHT' switch on/off.  
Turn the lights off when you leave the room.

**Maintenance****Cleaning:**

- Turn the power OFF.
- Wipe bulbs and fascia with care using a damp soft cloth with just a small amount of neutral detergent.

**Bulb Replacement:**

- Check and tighten the bulbs regularly.
- Turn the power OFF.
- Use max. 4 x 275W E27 R125 Infrared heat bulbs (EGLO part No.: ET3169)
- ONLY use designated bulbs, other bulbs may cause damage or danger.

**Warranty**

EGLO offers the original purchaser a repair or replacement of the EGLO product in cases where the product fails due to defective materials or workmanship, when installed and operated under normal domestic/residential conditions for 3 years from the date of original purchase. Refer to the Warranty booklet enclosed with this product for further details.

Imported by:

EGLO LIGHTING AUSTRALIA  
5/339 Archerfield Road  
Richlands  
Queensland 4077  
www.eglo.com.au

Made in China

EGLO  
my light | my style

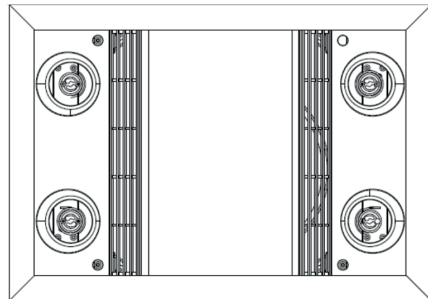
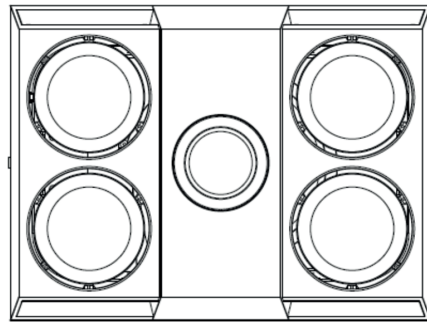
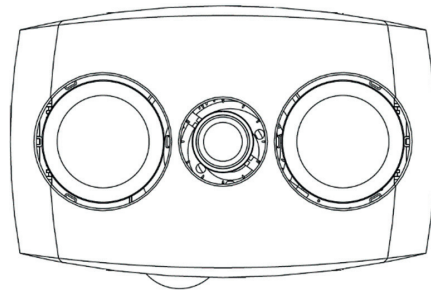

Warranty Information

**Bathroom Heater/Exhaust Fan/Light**

**204152, 204153**

**204154, 204155**

**204156, 204157**

**204158, 204159**

## **WARRANTY CLAIMS ON INSTALLED PRODUCTS:**

EGLO Lighting (EGLO) will not be liable for charges incurred by the consumer for rectification, deinstallation or re-installation unless approved by EGLO management in writing.

All claims are to be submitted in writing to head office with a copy of the original purchaser's receipt, a copy of the certificate of compliance or installers invoice including qualified installer licence number, and a completed Warranty Claims Form. Incomplete submissions will not be considered.

## **AUSTRALIAN CONSUMER LAW**

The benefits given to you the consumer in this warranty document are in addition to your other rights and remedies under a law in relation to the products to which this warranty document relates.

"YOUR CONSUMER RIGHTS": "Our goods come with guarantees that cannot be excluded under the Australian Consumer Law. You are entitled to a replacement or refund for a major failure and compensation for any other reasonably foreseeable loss or damage. You are also entitled to have the goods repaired or replaced if the goods fail to be of acceptable quality and the failure does not amount to a major failure."

Subject to "Your Consumer Rights" outlined above, but otherwise to the maximum extent permitted by law, EGLO will not be liable for any consequential or indirect loss or damage suffered or incurred by you in relation to an EGLO product, including but not limited to loss of use, loss or damage for business interruption, or profits.

## **LIMITED REPAIR / REPLACEMENT WARRANTY:**

EGLO offers the original purchaser a repair or replacement of the EGLO product in cases where the product fails due to defective materials or workmanship when installed and operated under normal domestic/residential conditions for 3 years from the date of original purchase. The warranty period begins from the date of purchase. Also, please refer to WHAT IS NOT COVERED.

You must provide proof of purchase (such as the original dated purchase receipt/invoice) from an authorised EGLO reseller to make a warranty claim. You must also provide a certificate of compliance or installers invoice including qualified installers licence number. Warranty claims submitted without this documentation WILL NOT BE ACCEPTED. This warranty will not apply if the 3 in 1 Bathroom Heater/Exhaust/Light is installed by anyone other than a qualified and licensed electrical contractor.

Light & Heat bulbs/lamps (if supplied) are done so as a complimentary (free) item only, and are not covered by warranty.

### **REPAIRS / REPLACEMENTS**

EGLO products presented for repair may be replaced by refurbished goods of the same type rather than being repaired at the discretion of EGLO. Refurbished parts may be used to repair the goods to proper order.

### **BALANCE OF WARRANTY**

To the maximum extent permitted by law, any product replaced, repaired, or refurbished by EGLO is covered only by the balance of the warranty period remaining from the date of original purchase of the original EGLO product.

## **WARRANTY TRANSFER:**

If the ownership changes on the dwelling/premises where the EGLO product is installed, the balance of the warranty period passes to the new owner provided the original proof of purchase (such as the original dated purchase receipt) from an authorised EGLO retailer is retained by the new owner. In addition, a certificate of compliance for the installation from the installing electrician is required for products requiring installation by licensed electricians. Failure to transfer of these documents will result in the balance of the warranty being void.

## **WHAT IS NOT COVERED:**

Subject to "Your Consumer Rights", but otherwise to the maximum extent permitted by law, the EGLO warranties provided in this document will not cover the following:

1. EGLO products that are not purchased from an authorised retailer in Australia and installed in Australia.
2. Where installation was not carried out by a qualified and licensed electrical contractor or where evidence of

installation by a qualified and licensed electrical contractor cannot be presented.

3. EGLO products not installed in accordance with the product's installation instructions.
4. EGLO products not operated in accordance with the instructions for use, or specifications.
5. Defect, damage, or failure to a EGLO product resulting from misuse, accident, neglect, abuse, tampering, modifications or unauthorised repairs of any kind by any person.
6. Damages not caused by a fault in the EGLO product materials or workmanship.
7. Defect, damage, or failure to a EGLO product resulting from any acts of God, including damages from lightning, power grid fluctuations, or power surges.
8. Replacement of light sources (globes/lamps/bulbs) unless specified.
9. Damage caused by alternative power systems (for example: solar inverters, etc.).
10. Damage caused by over-tightening or under-tightening of bulbs and/or terminals.
11. Water damage of any kind caused by inappropriate placement of fittings not IP rated for that location, or inadequate ducting installation allowing condensation running back into the fan housing.
12. Transportation and in-transit insurance costs, if the product or parts thereof must be returned for repair or replacement to the retailer or the authorised service agent.

#### **COMMERCIAL USE:**

EGLO products which are specifically designed for commercial use are designated as Commercial Use Products on the product packaging. All other EGLO products are designed for domestic use only. This product is not designed or intended for industrial or commercial use.

#### **WARRANTY CONDITIONS:**

- This warranty is for 240V 50Hz products originally purchased and installed in Australia ONLY.
- Installation must be performed by a qualified and licensed electrician. The warranty will not apply if the product is installed by other than a qualified and licensed electrician.
- Problems arising from incorrect installation are not covered by warranty.
- The cost of repairs arising from incorrect installation, not due to faulty material or workmanship in accordance with the EGLO warranty, will be payable by the purchaser.
- This warranty is only valid for appliances used according to the manufacturer's instructions.
- The manufacturer does not accept liability for any direct or consequential damage, loss or other expense arising from misuse or incorrect installation and operation of the appliance.
- Warranty will only be provided where proof of qualified electrical installation is provided. E.g. Electrical Safety Certificate.
- The manufacturer will not accept in home expenses unless authorisation is granted prior to work commencing, and a ARN number allocated by EGLO.
- This product is not designed or intended for industrial or commercial use.

#### **HOW TO MAKE A WARRANTY CLAIM:**

Limited repair/replacement warranty: Please return the faulty EGLO product together with a copy of the proof of purchase, and if required, a certificate of compliance for the installation of the product by the licensed electrician who installed the product, to the authorised EGLO retailer where the product was purchased. To the maximum extent permitted by law, the customer must bear the costs and expenses of claiming under this warranty, including but not limited to the cost incurred in freight, postage, handling, travel, dismantling or reinstalling the product.

IN THE CASE OF MISSING ACCESSORIES OR PARTS, PLEASE CONTACT EGLO CUSTOMER SERVICE BEFORE COMMENCING INSTALLATION OF THE PRODUCT.



Please keep this warranty card in a safe place. This card must be produced in the event of a fault.

## WARRANTY CLAIM FORM

<b>PURCHASE DETAILS</b>			
Store Name:			
Date of Purchase:		Receipt:	YES <input type="checkbox"/> NO <input type="checkbox"/>
Contact Person:		Store Ph.:	

<b>CUSTOMER DETAILS</b>			
Name:			
Adress:			
City, Suburb:		State:	
Postcode:		Ph-Home:	
Ph-Mobile:		Ph-Work:	
Email:			

<b>INSTALLER DETAILS</b>			
Name:			
Licence No.:		Install Date:	
Cert of Elect Safety:	YES <input type="checkbox"/> NO <input type="checkbox"/>	PH - Mobile:	
Email:			

<b>PRODUCT DETAILS</b>				
EGLO Model No.:	204152 <input type="checkbox"/>	204153 <input type="checkbox"/>	204154 <input type="checkbox"/>	204155 <input type="checkbox"/>
	204156 <input type="checkbox"/>	204157 <input type="checkbox"/>	204158 <input type="checkbox"/>	204159 <input type="checkbox"/>
Fault Details:				

<b>EGLO USE ONLY</b>			
Date:		Electrician:	
Quote No.:		Cost to Rectify:	
Approved By:		Signed:	

Complete this form, and return with your faulty product, and a copy of your purchase receipt and installers invoice to the place of purchase. For assistance, email **EGLO LIGHTING**: [warranty@eglolighting.com.au](mailto:warranty@eglolighting.com.au)